



VENICE
CITY

Eternal
—*—*—

Mirchi Family Success Event



Welcome to Mirchi Developers

Completed Projects



Open Plots

@Dundigal - Gandimaisamma

Handovering Project



Villa

@Pati - Kollur

Upcoming Project



Villa

@Nandigama - Kollur

Spacious
Independent
Living...



The soul is healed by being with Children.



★★★★★
5 Star Rated
Villa Elevation

Fusion of Nature and Urban Comfort...

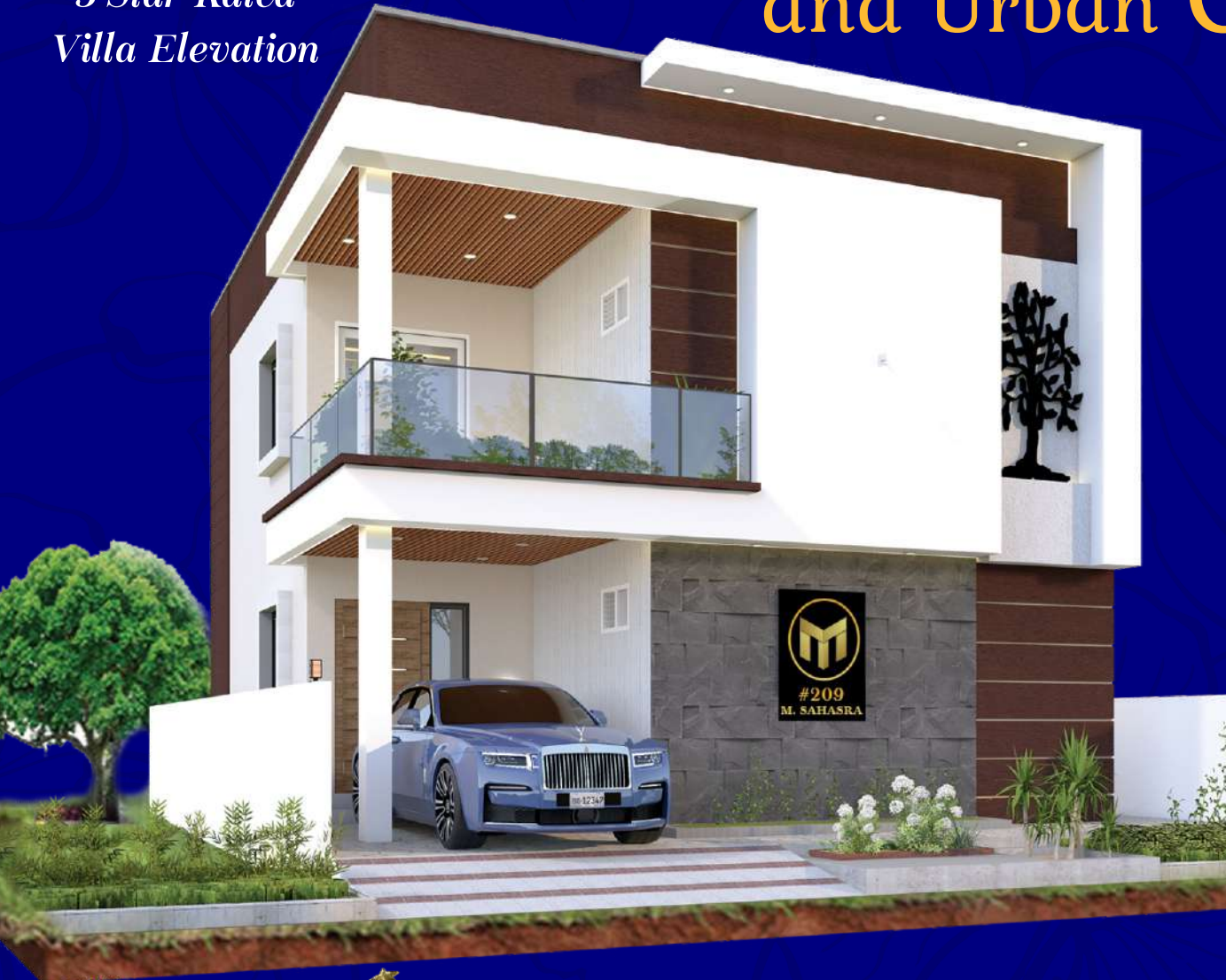

PERFECT
ENVIRONMENT



PERFECT
LOCATION

PERFECT
AMENITIES



PERFECT
CONNECTIVITY

PERFECT
INVESTMENT



PERFECT
SECURITY



Visit Our Award Winning Model Villa



North East Corner Villa



NORTH EAST Facing | 394 Sq.yds | PLOT SIZE: 71'x 50' | TOTAL BUILT-UP AREA - 5514

East - Facing Villa View

*Residence
Where you can
find **Luxury***



EAST Facing | 183 Sq.yds | PLOT SIZE: 33'x 50' | TOTAL BUILT-UP AREA - 2599

East - Facing Villa Street View



A PERFECT BLEND OF LUXURY WITH SERINITY...

- East Model Villa Authentic Interior Images -



Living Hall



Master Bedroom

Real interior images.



Children's Bedroom



1st Floor Living Hall / Home Theatre

West - Facing Villa View

Residence
Where you can
find Peace



WEST Facing

165 Sq.yds

PIOT SIZE: 33'x 45'

TOTAL BUILT-UP AREA - 2230

West - Facing Villa Street View



A PERFECT BLEND OF LUXURY WITH SERINITY...

- West Model Villa Authentic Interior Images -



Living Hall

Real interior images.



Master Bedroom



Kids Bedroom



Dining Area



To Celebrate the Joy of Life
15000+ Sft Fully Loaded Clubhouse





*Clubhouse
&
Swimming Pool*



30+ WORLD CLASS AMENITIES

The M Club Community is a group of like minded and forward thinking individuals, connected with a common way of living. The club brings together remarkable people with ambitions and ideas, forming beneficial and lasting connections. M Club community is exposed to accurate lifestyle experience that is customized and at the same time sets a vibrant and stimulating environment.

- A Lavish and Independent Club House Consist of G+2 Floor
- Indoor and Outdoor Games
- State of the Art Gym
- Yoga Hall
- Banquet Hall
- Multipurpose Hall
- Cricket Net
- Swimming Pool
- Shuttle Court
- Basketball Court
- Cafeteria
- Hospital & Pharmacy
- ATM
- Beauty Parlour & Spa
- Two Guest Rooms
- Meeting Hall
- Office Room
- Walking & Cycling Track
- Terrace Party Area
- Cards Play Room
- Children's Play Area
- Beautiful Landscaping
- Water Softening Plant
- Power Backup for Common Areas
- 500kv Generator Facility for common areas & for the Villa excluding AC & Geyser
- Rain Water Harvesting Pits
- Solar Fencing Boundary Wall
- 1 Lakh Litres Overhead Water Tank
- Unique Villa Owner Name on Every Villa
- Super Market



***5.5 ACRES GOVERNMENT SPORTS COMPLEX
OPPOSITE OF OUR VENICE CITY EXIT GATE**

We may have our differences, but nothing is more important than Family.





Shuttle Court

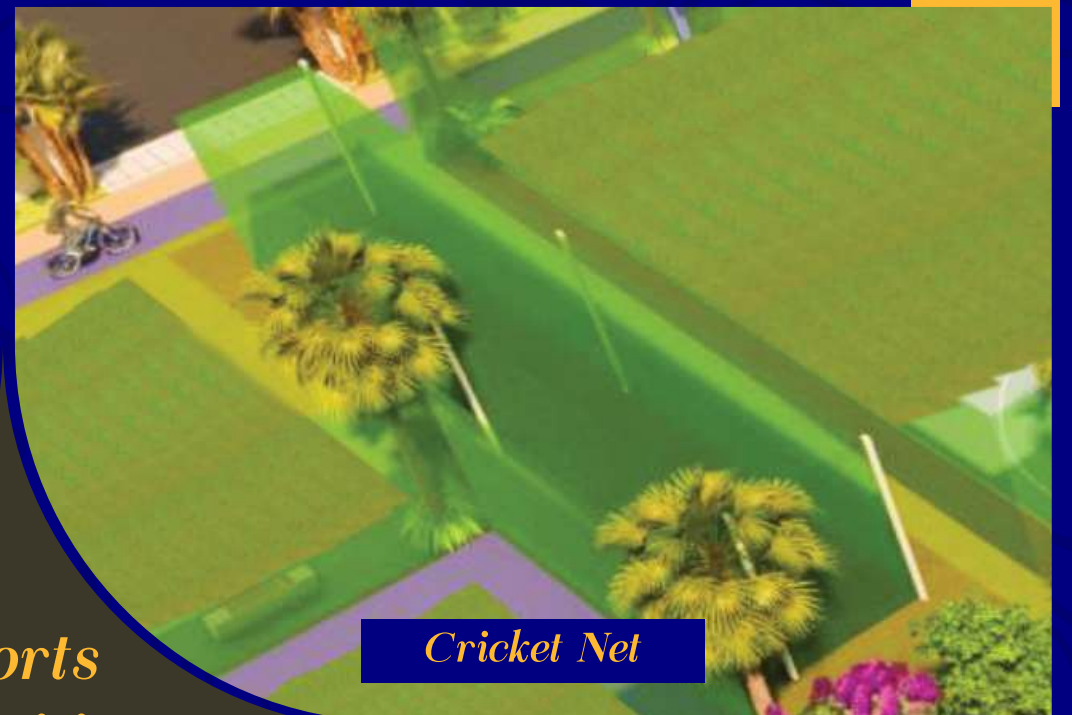

Cricket Net

*Sports
Amenities*



Walking & Cycling Track



Basketball Court



Super Market



Meeting Hall

Club House Amenities



Gym



Office Room

Lounge & Park Areas

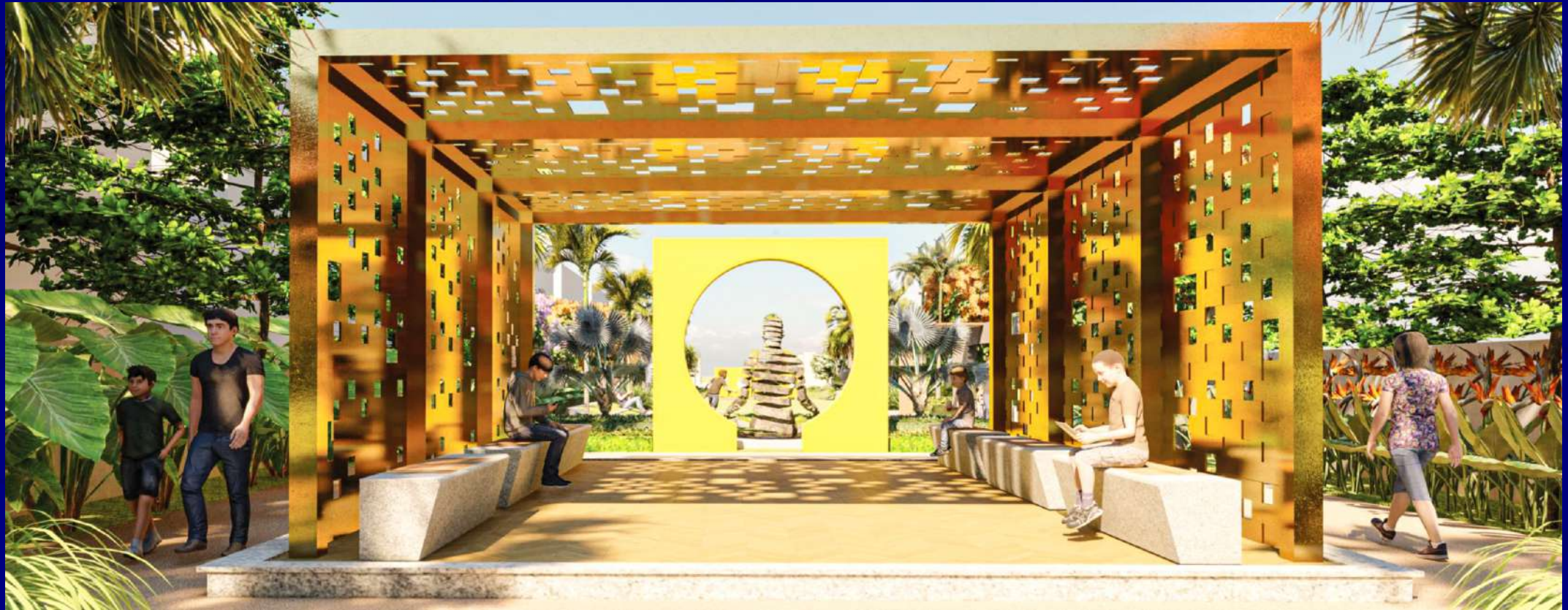



Play Area



Outdoor Games Area

*Kids
Play Zone*



Garden Area



Indoor Games Area



Clinic & Pharmacy



Spa

Other Existing Amenities



Banquet Hall



Guest Room



1 Lakh Ltrs Overhead Water Tank



CC Roads

Other Existing Amenities



Unique Villa Owner Name on Every Villa



Outdoor Games

*Make way for a lifestyle **Un-Experienced***

If all that you've wanted to experience is a life of incredibleness in the company of homes that share unparalleled class and elan, Venice City is the place to settle in. Each home is an inspiring example of bespoke design and solid construction, crafted by minds that know what you expect after having arrived up there in life. So here it comes, a life of pride accompanied by a lifestyle of total refinement.



Real Images of the Project



A PROJECT BY



Total Extent of Land: 16 Acres

Total Villas: 247

Project Approved by: HMDA & TS RERA

LP Number: 03/LO/PIg/HMDA/2020

BANKING PARTNERS



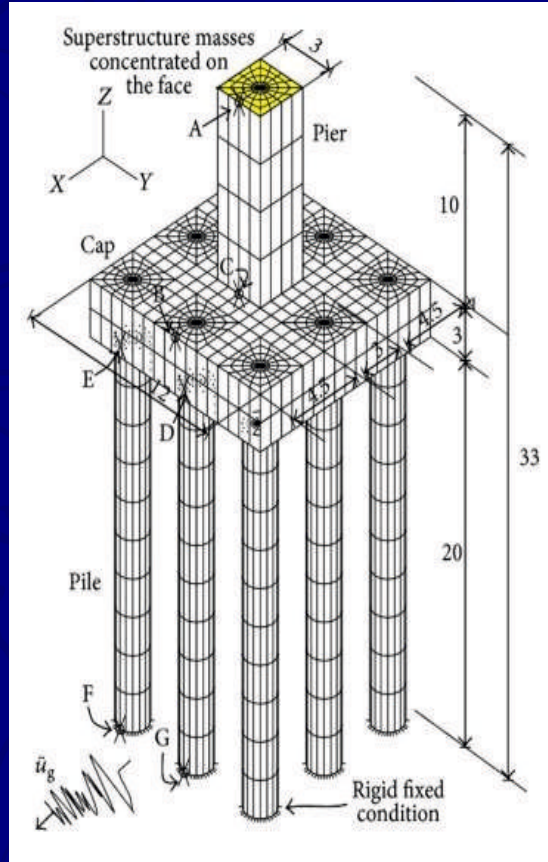
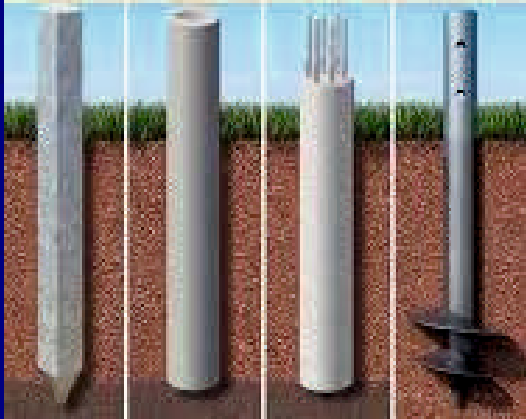
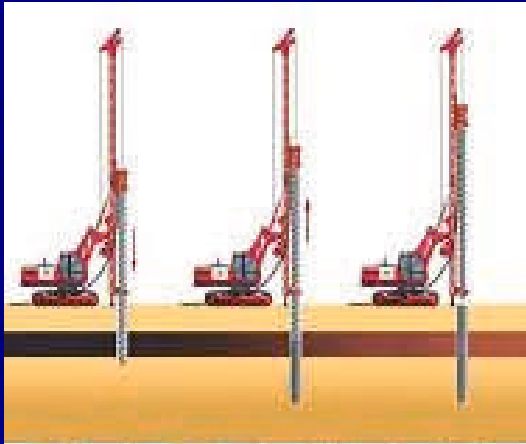

Strong & High Quality

If you are looking for strong, durable and high quality Villas build with Piles Foundation with top class finished. Then look no further homes in our projects are built using Piles Foundation. This is the right project for you...





A PROJECT BY



MIRCHI
DEVELOPERS

Where dreams come home...

WHY?

*Best Emerging
Premium Villa Award
From
Times of India*

- 🏆 Implementing Innovative Technology
- 🏆 Quality Construction
- 🏆 Affordable Pricing with Luxury
- 🏆 Trust Worthy Team
- 🏆 Handpicked Premium Locations
- 🏆 Building Spacious Homes in Limited Land
- 🏆 Great Return on Investment
- 🏆 Committed Management
- 🏆 Hassle Free Land Titles (Own Lands)
- 🏆 Experts at Creating Sustainable Living



Venice City Specifications

Foundation:

RCC Framed Structure of Ground Plus Upper One Floor.

Walls:

6"/8" Thick External Wall, 4"/4".
Internal Wall with Cement Brick or AAC blocks.

Plastering:

Two Coat plastering for both Interior and Exterior Walls.

Doors, Door Frames and shutters:

All Doors, Door frames and shutters Duradoor from NCL, DEC or Equivalent Group.

Painting:

- I. Internal and Ceiling painting: 2 Coat Putty + 1 coats of Primer + 2 coats of emulsion paint (Asia / Birla / JK / Berger / Techno Paint or Equivalent)
- ii. External Painting: 2 Coats Putty + 1 Coat of Primer + 2 coats of External weather proof paint (Asia / Birla / JK / Berger or Equivalent).

Electrical:

- I. All Wiring Dr. Copper or Equivalent Switches / DB of Dr. Copper / Legrand or Equivalent.
- ii. Power point Provisions for Ac's for all bed rooms and Geysers in bathrooms.
- iii. Internet Provision at ground Floor and provided TV. Cabling Provisions for all bedrooms.

Flooring:

- i. Vitrified Tiles in Drawing, Dinning and Bedrooms, Lounge, & So many. Asian, Muranoor or equivalent Brands.
- ii. Wooden Flooring in Master bed room.
- iii. Staircase: Combination of Elegantly designed Granite or Equivalent.
- iv. Bathrooms: Antiskid Ceramic tiles with glazed tiles dado upto 7' height.
- v. Utility: Antiskid Ceramic tiles with glazed tiles dado upto 4' height.
- vi. Balconies: Antiskid vitrified tiles flooring.
- vii. Top Terrace: Water Proofing Treatment as per standards.

Plumbing:

- a. CPVC pipe provided for sewerage supply lines (Vectus / Ashirvad / Astral or Equivalent).
- b. CPVC pipes provided for water supply lines (Vectus / Ashirvad / Astral or Equivalent).

Kitchen:

- I. Granite Platform with Stainless Steel Sink.
- ii. Provisions in kitchen: for fixing of water purifier, exhaust fan and chimney.
- iii. Up To 2' feet dado finishing tile.

Softner:

Water Softening Plant will be provided for community.

Water Supply System:

Centralized water distribution by hydro pneumatic system for all villas.

Windows:

All Grill & UPVC Windows and Mesquito Windows French NCL doors.

Bathroom Fittings:

Grohe, Jaquar, Parryware, CERA, Hindware or equivalent brands.

Power Backup:

- i. DG Power upto 1kv to each villa.
- ii. 500kv DG Power Backup for common areas.

Car Parking Area:

Granite Stone.

CC Cameras:

CC Camera provision for each villa.

Railing:

Elevation Balcony SS Railing with glass Stair case SS Railing.



Highlights of the Project

- HMDA Approved Project
- 16 Acres Project
- 247 Luxury Duplex Villas
- 200 feet and 100 feet Road Two Way Connectivity to Venice City
- Premium Location in Hyderabad
- Fully Developed Surrounding Areas
- As per Vastu
- Street Lights
- Over Head Water Tank
- Sewerage treatment plant
- 40 & 30 feet Internal CC Road
- Immediate appreciation
- More Open Area
- Under Ground Drainage & Electricity
- Fully Loaded Club House
- Plenty of Plantation
- Only East & West Facing Villas
- Near to All IT Hubs
- Near to Financial District
- Near to Gachibowli
- Very near to Ring Road Exit no. 02 & 03
- Inside the ring road



WATER SOFTENING PLANT



FUNCTION HALL



COMMUNITY DINING



LANDSCAPED GARDEN



CLINIC WITHIN THE CAMPUS



SEWAGE TREATMENT PLANT



AYURVEDIC SPA



BEAUTY SALOONS FOR MEN & WOMEN



GUEST ROOMS



FULLY EQUIPPED GYMNASIUM



INDOOR GAMES ROOM



SHUTTLE COURT



POWER BACKUP



INTERCOM FACILITY



PROVISION FOR SOLAR WATER HEATER FOR VILLAS



SWIMMING POOL



ATM



24 HRS SECURITY WITH CCTV SURVEILLANCE



Venice City Aerial View



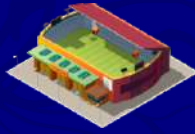

5.5 Acres
Municipal Stadium

200' Ft Road

Master Layout Plan

Shankarpalli to Patancheruvu

- 165 Sq.yds
- 183 Sq.yds
- 133 Sq.yds - 394 Sq.yds

Shankarpalli Road to Pati - Kolluru

100' Ft Road





50' EAST ROAD

East Facing
Ground Floor Plan



East Facing
First Floor Plan



East Facing
Terrace Floor Plan



EAST Facing | 183 Sq.yds | PLOT SIZE: 33'x 50' | TOTAL BUILT-UP AREA - 2599



30' WEST ROAD

West Facing
Ground Floor Plan



West Facing
First Floor Plan

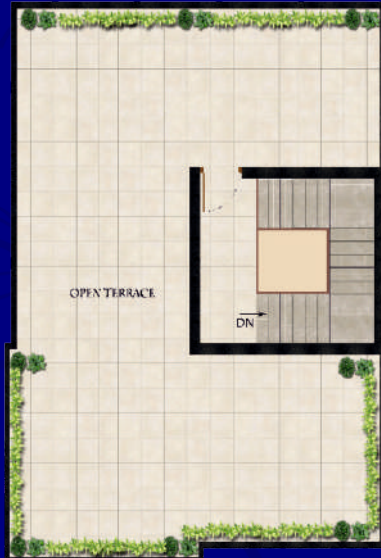

West Facing
Terrace Floor Plan



WEST Facing

165 Sq.yds

PIOT SIZE: 33'x 45'

TOTAL BUILT-UP AREA - 2230

“5 Minutes Drive from Kollur IT HUB”



Venice City is a hot cake property at the most happening place in Kollur where the new IT Hub is also taking shape.

Luxury and work match to create a fabulous lifestyle. Enjoy it.

Educational Institutions

Gaudium International School: 07 Minutes
Samashti International School: 07 Minutes
Candiidus International School: 07 Minutes
International School of Hyderabad: 17 Minutes
Birla Open Minds International School: 07 Minutes

Hospitals

Continental Hospital: 20 Minutes
Citizens Speciality Hospital: 25 Minutes
AIG Hospital: 25 Minutes
Care Hospital: 25 Minutes

Shopping Malls

GSM Mall: 20 Minutes
Sarath City Capital Mall: 30 Minutes
Inorbit Mall: 30 Minutes

IT Hubs

Kollur IT Hub: 05 Minutes
Financial District: 15 Minutes
Gachibowli: 20 Minutes
Hitech City: 30 Minutes

Nearby

ORR Kollur Exit No. 2: 03 Minutes
ORR Patancheruvu Exit No. 3: 03 Minutes
Patancheruvu - Mumbai Highway: 05 Minutes
BHEL: 15 Minutes
Lingampally MMTS Railway Station: 20 Minutes
Google Office: 15 Minutes
Amazon Office: 15 Minutes
Rajiv Gandhi International Airport: 45 Minutes





Outer Ring Road Exit 3

ISNAPUR
ఇస్నాపూర్

Shankara Palli Road

BACHUPALLY
బాచుపల్లి

Candidus In
Sch

Patancheruvu

Allwyn X Road

JNTU
కె.జె.సోమయాజీ నగర్

KPHB Metro

Nandigaon
నందిగామ

Kardalur

Venice City

BHEL

Serilingampalle
(M)
శేరిలింగంపల్లి

HAFEEZPET
హఫీజ్ పేట్

KHATAPALLY
ఖాతాపల్లి

KPHB 5th Phase

The Gaudium School

Edulanagulapalli Exit 2

TELLAPUR
తెల్లూపూర్

PVR Nexus Mall
Kondapur
కొండాపూర్

Edulnagulapally
ఎదులనగులపల్లె

Gachibowli

Gopanpalle
గోపనపల్లి

MADHAPUR

IKEA Store

KOLLU
కొల్లూర్

GACHIBOWLI
గచ్చిబౌలి

Nehru ORR Exit 1

Vasavi Sky City

Vattinagulapalle
వట్టినాగులపల్లి

Nanakaramgula
నానాకరామ్ గుడ

Manikonda
Jagir
మణికోండ

Donthanpalle
దొంతన్నపల్లి

Proddutur
ప్రోద్దుటూరు

Janwada
జన్వాడ

Chinna
Mangalaram
చిన్నమంగాలారం

Gandipet
గండిపేట్

Narsingi
నార్సింగి

Reddipally

MEH
మె

Park Aerial View



TOP VIEW

Temple
for our Community



Dedicated Feeder
for our Community





Site Address:

Pati - Kollur (Pati to Gaudium School Road)
Patancheruvu Mandal, Sangareddy Dist, Hyderabad.



Corporate Office Address:

3rd Floor, Bizness Square, Hitech City Rd, Laxmi Cyber City,
HITEC City, Hyderabad, Telangana 500081.

Contact us:



+91 7330611128



Email: sales@mirchidevelopers.com



website: www.mirchidevelopers.com



LEGAL DISCLAIMER: All depictions of interiors, furniture, fixtures, are conceptual only and are not included in your house. The photos contained in the marketing collaterals such as marketing brochure, sales kits, walkthroughs etc. may be stock photographs or have been shot off site and are used to depict the lifestyle to be achieved. All drawings in the marketing collaterals are illustrations and not actual images. The plans are subject to changes based on final approvals from state government, HMDA, RERA & local bodies. Prospective buyers are advised to visit Mirchi sales office and verify floor plans and other parameters before making a buying decision.

This marketing collateral is purely conceptual and does not constitute a legal document. Visual representation are not to be taken as representation of facts and do not form part of an offer or contract. The management of Mirchi group reserves the right to add, delete or alter any specification mentioned here.

